

THIS DRAWING IS AN OVERALL REPRESENTATION OF THE APPARATUS AS PROPOSED.

THE EXACT LOCATIONS OF ACCESSORIES OR COMPONENTS MAY BE REVISED PENDING COMPLETE ENGINEERING REVIEW OF THE OPTION CONTENT OF THE ORDER.

IF THERE IS A DISCREPANCY BETWEEN THE BODYBUILDER PRINT AND THE WRITTEN PROPOSAL, THE SPECIFICATIONS WITHIN THE PROPOSAL PREVAIL.

This drawing along with any changes made and initialed by both the "Fire Department" & H.M.E., Inc. represents what will be constructed and supplied to the "Fire Department". Any changes to the contract specifications and drawing after today's date will be addressed via appropriate change order signed and approved by both the "Fire Department" & H.M.E., Inc.

TITLE: \_\_\_\_\_  
FIRE DEPARTMENT

TITLE: \_\_\_\_\_  
H.M.E. Incorporated

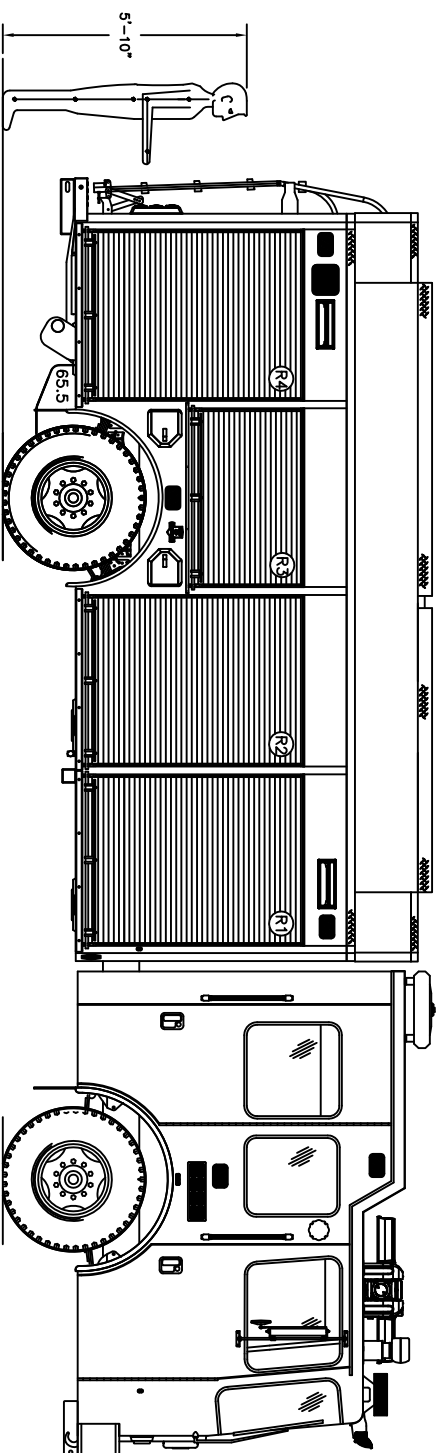
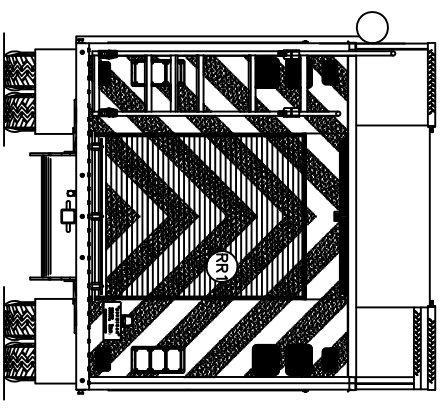
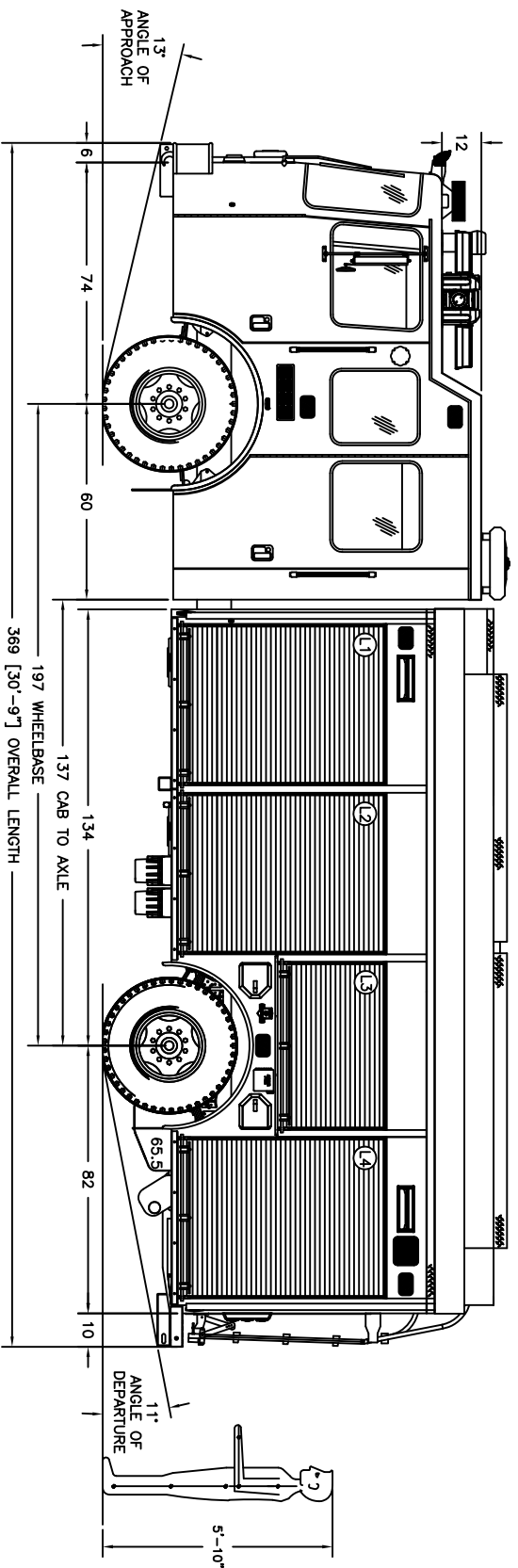
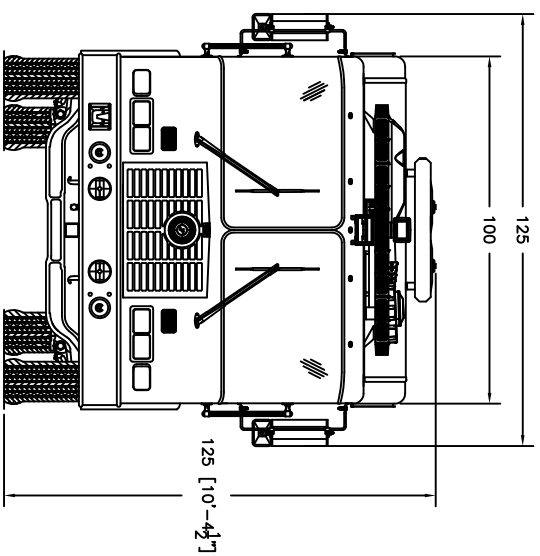
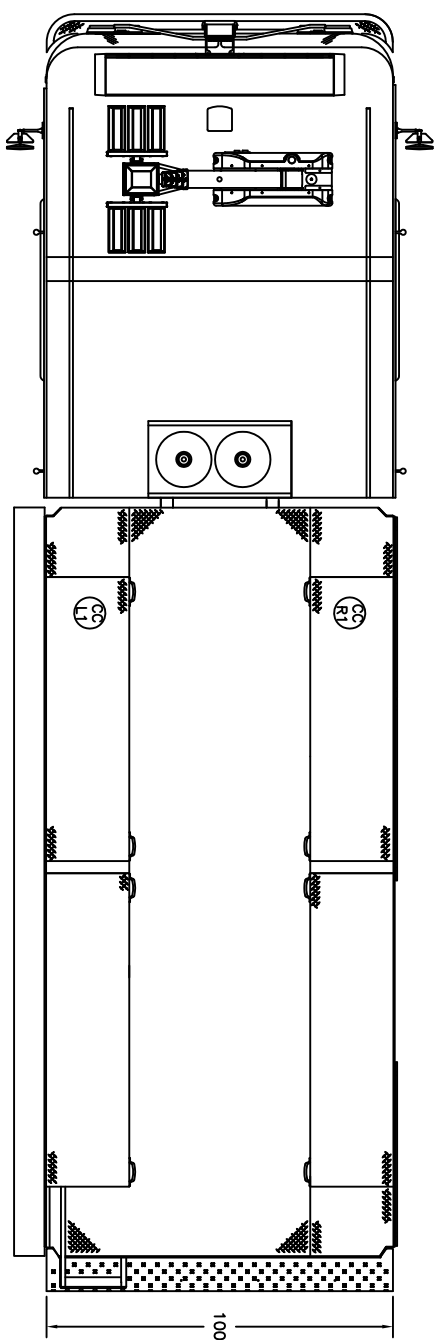

BEHIND DOOR		CLEAR OPENING		COMPT. VOLUME		
COMPT.	WIDTH	HEIGHT	DEPTH	WIDTH	HEIGHT	
L1/R1 UPPER	56	60	97	48	57	188.6FT <sup>3</sup>
L1 LOWER	56	17	24	48	57	13.2FT <sup>3</sup>
R1 LOWER	56	17	24	48	57	13.2FT <sup>3</sup>
L2/R2 UPPER	51 1/2	60	97	48	57	173.5FT <sup>3</sup>
L2 LOWER	51 1/2	17	24	48	57	12.2FT <sup>3</sup>
R2 LOWER	51 1/2	17	24	48	57	12.2FT <sup>3</sup>
L3/R3	51 1/2	47	97	49	28 1/2	135.9FT <sup>3</sup>
L4/R4 MIDDLE	23	60	48	-	-	38.3FT <sup>3</sup>
L4 OUTER	51 1/2	77	24	48	57	55FT <sup>3</sup>
R4 OUTER	51 1/2	77	24	48	57	55FT <sup>3</sup>
OCL1	179 1/2	22	25	(2X)85 1/2	(2X)23 1/2	57FT <sup>3</sup>
CCR1	179 1/2	22	25	(2X)85 1/2	(2X)23 1/2	57FT <sup>3</sup>
RR1	48	76	32	46	57	67.5FT <sup>3</sup>

COMPARTMENTATION

CREATED WITH AUTOCAD®



1950 BYRON CENTER AVE.  
WYOMING, WY. 83099

THIS PRINT IS PROVIDED ON A RESTRICTED BASIS AND IS NOT TO BE USED IN ANY WAY DETRIMENTAL TO THE INTERESTS OF H.M.E., INC.

NAME: MOULTONBOROUGH FIRE RESCUE DEPARTMENT

DRAWN: J. LEE DATE: 12 APR 12 APPROVED: N/A DRAWING FILE: MOULTONBOROUGH FIRE DEPT.DWG

SIZE: B NUMBER: MOULTONBOROUGH, NH SCALE: 1/8" = 1'-0" SHEET: 1 OF 1

LET	BY	DATE	REVISION
A	JML	12 APR 12	ORIGINAL RELEASE